



**WARNING:** Please take the time to read through the ENTIRE instructions prior to starting any work. Not following the instructions will invalidate the warranty.

## Important Precautions & Helpful Hints...

- The Light Pipe material is very sharp when cut. Please use extreme caution when handling the light pipe.
- The Light Pipe is highly reflective, use proper eye protection when installing. Avoid leaving the pipe exposed to the sun without the protective coating. (The protective coating shouldn't be removed until Step 6.)
- Ensure normal safety precautions are taken when using tools and walking on roofs.
- Do not cut any structural members in the house.
- Ensure overhead utility line, wire runs and plumbing or ventilation ducts will not interfere with the light pipe installation.
- Measure twice and cut once.

## Components and Hardware Parts List:

- A. Clear UV Protected, High Impact Acrylic Dome
- B. Phillips Head Stainless Steel ¼" Self-Tapping Screws
- C. Black Horsehair Gasket (self-adhesive)
- D. 1 ½" Phillips Flat Head Stainless Steel Screws
- E. Commercial Pure Grade, 1100 Series Aluminum Flashing
- F. Light Pipe, 24" sections
- G. Heavy Duty Foil Tape
- H. Phillips Head Stainless Steel ½" Self-Tapping Screws
- I. White Horsehair Gasket (self-adhesive)
- J. White Powder Coated Transition Box
- K. LED Quadrants
- L. White Washers
- M. 1" Self Tapping Tek Screws
- N. Wire Nuts
- O. LED Driver
- P. LED Driver Enclosure
- Q. Caulk

## Tools Needed:

- Channel Locks
- Step Down Drill Bit
- Hammer
- Stud Finder
- Diver & Bits
- Tin snips
- Clamps
- Measuring Tape
- Reciprocating Saw
- Phillips Screwdriver
- Marking Pencil

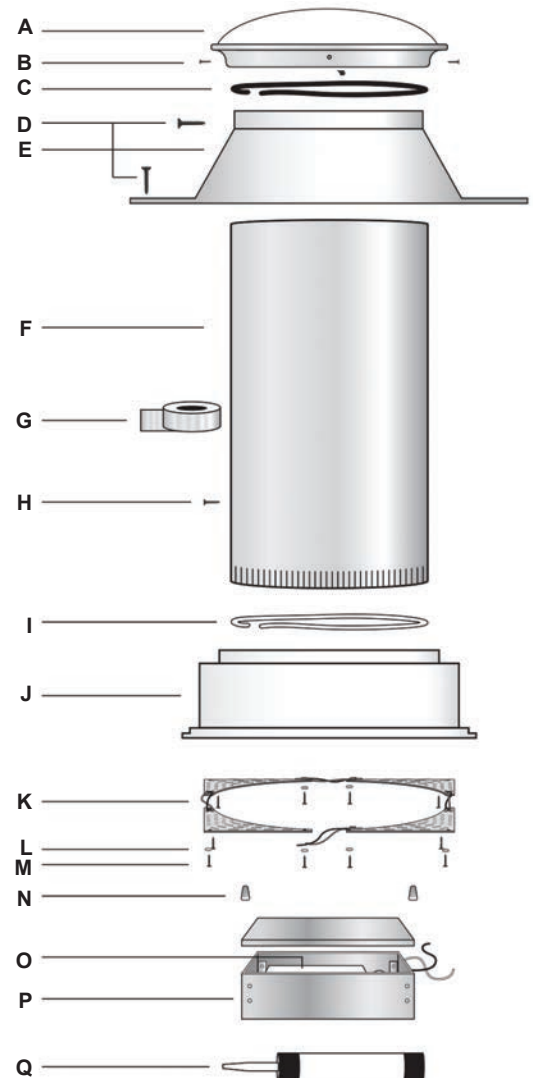

Please allow 2 hours to complete the installation. Components and hardware are referenced to the corresponding numbers on the parts list on the front page.

**STEP 1** For the roof cutout, choose the location for the tubular skylight installation. If the drop ceiling is already installed, remove the ceiling tile that the tubular skylight Transition Box (J) will replace. Set up a ladder under the location and place a flashlight on top of the ladder, the resulting flashlight beam will mark the location for the centering hole of the flashing unit on the roof.

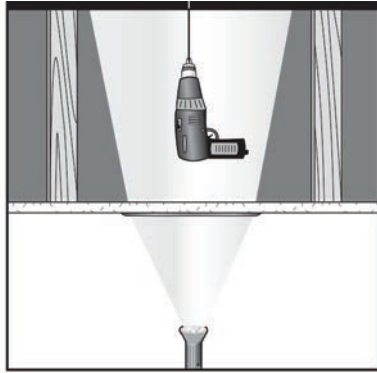

With a drill bit and appropriate extension rods, drill a pilot hole in the marked location on the bottom side of the roof.

**STEP 2** On the roof, locate the centering hole and outline the diameter of the hole that the pipe will pass through by turning the Flashing (E) upside down and marking the inside lip of the flashing unit (see diagram).

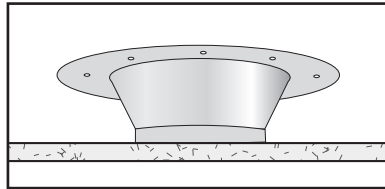

**STEP 3** With a reciprocating saw, cut the diameter of the hole 1" larger than the area marked in Step 2.

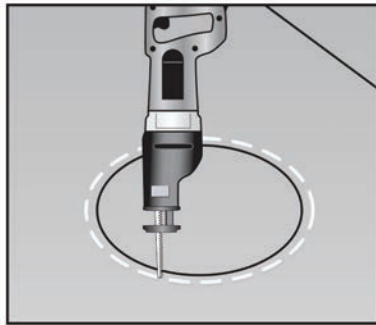

**IMPORTANT: The light pipe must pass between the roof rafters. DO NOT CUT THROUGH ANY FRAMING MEMBER.**

**STEP 4** Caulk underside of flashing with the provided caulking material (Q). Two concentric rings of caulking material are sufficient. Turn flashing right-side-up and center over hole cut in Step 3. Press firmly down on flashing until caulk slightly squeezes out at the lip of the flashing.



**STEP 5** Peel the protective backing off the black horsehair gasket (C) and apply gasket on the inner lip of the flashing collar. Secure flashing with (8) Phillips head 1 1/2" screws (D) provided. Evenly space the screws around the lip of the flashing. Place first screw at the 12 o'clock position, then next directly across from it at 6:00. The third screw should go at 9:00 and the next screw directly across at 3:00, etc. Caulk over the screw heads, since they will be exposed to the weather.

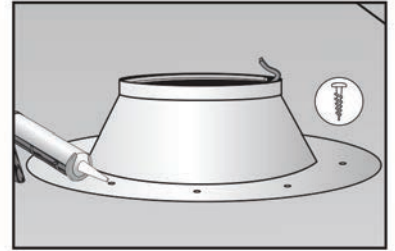

**STEP 6** To assemble light pipe (F), peel back the protective coating that covers the mirror coating about 1" from the opposite edge of the double-sided tape. Remove paper backing from the double-sided tape and overlap tube ends and seal edges. Put pressure on both sides of seal to ensure a good bond. Secure tube using the (2) 1/2" self-tapping screws (H) provided. Then place foil tape (G) over the entire seam to strengthen seal. When joining two pipe sections together, place crimped end into the next section of pipe. Secure the connection of the two sections of light pipe with (2) 1/2" self-tapping screws provided and seal joints with foil tape (G).

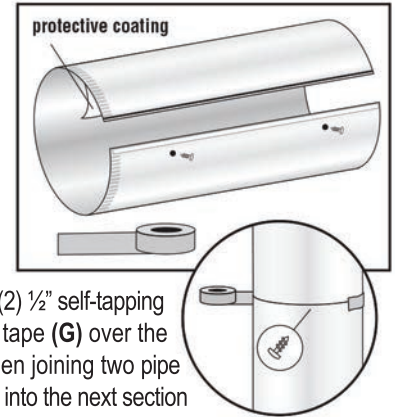

**STEP 7** In the room below, Remove the existing Diffuser by pulling down on the two small tabs on the outside frame of the Transition Box.

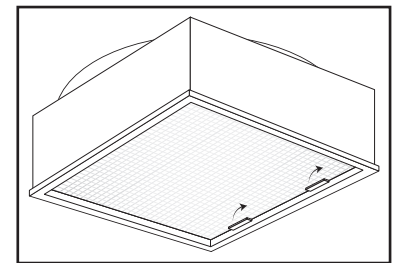

**STEP 8** Peel the protective backing off the white nylon horsehair gasket (I) and apply gasket on the INSIDE COLLAR OF THE TRANSITION BOX (J) 1/2" down from top of the collar.

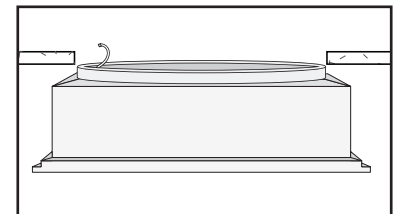

**STEP 9** Place a White Washer (L) on each of the twelve #6 x 3/4 Tek Screws and place the screws through the pre-punched holes on the LED Quadrants (K). Make sure you place the screws in from the blue/grey side with exposed LEDs (bottom).

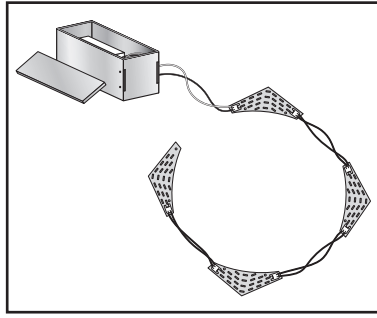

**STEP 10** One by one, place and secure the LED Quadrants into the each corner of the Transition Box by drilling the screws into the Transition Box, so that the LEDs face downward towards the room and quadrants are flush against the transition box.

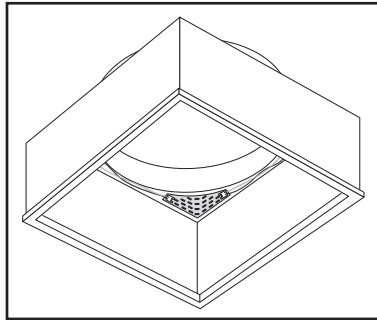

**STEP 11** Drill a 1/4" hole through the transition box close to the LED Quadrant with the loose wire. Feed the wire through the hole so it can connect to the LED Driver (O).

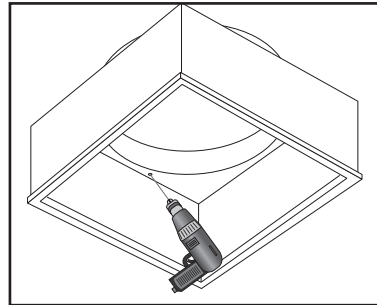

**STEP 12** Open the LED Driver Enclosure (P) and feed the loose wire from the LED Quadrant up the hollow, threaded bolt and into the LED Driver Enclosure.

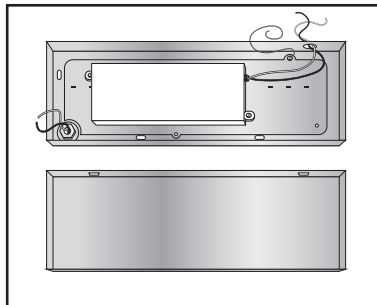

**STEP 13** Using the Wire Nuts provided, connect the loose wire from the LED Quadrant to the LED Driver; make sure the positive wire connects with the positive wire and the negative with the negative. Close the LED Enclosure.

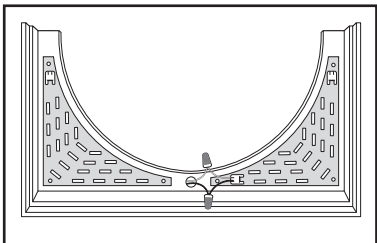

**STEP 14** Secure the LED Driver Enclosure to the Transition Box by feeding the hollow, threaded bolt through the 1/4" hole cut in step and tightening one nut inside the Transition Box and one nut outside of the Transition Box.

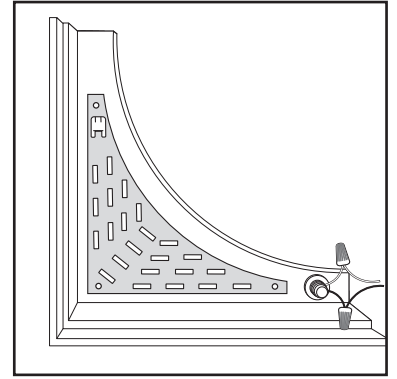

**STEP 15** Replace the Diffuser on the Transition Box by placing the flat tabs inside the frame first and then pushing the diffuser in place.

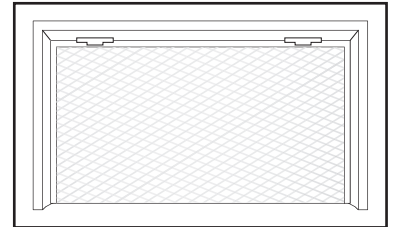

**STEP 16** Install the Transition Box into the ceiling grid system.

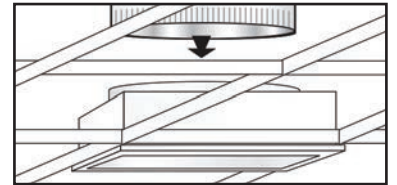

**STEP 17** From the roof, slide the light pipe assembly with the crimped edge down into the transition box collar. Secure the light pipe to the flashing with the (4) Phillips flat head 1 1/2" screws (D) provided through the (4) pre-drilled holes on the flashing lip. (To prevent light pipe from slipping through the hole, clamp light pipe to flashing or have someone hold it in place until it is secured.) If there is excess pipe sticking out of the flashing, using tin snips, cut from the top down to the lip of the flashing and trim off the excess pipe. (Use caution when handling the light pipe - edges of the light pipe are extremely sharp when cut).

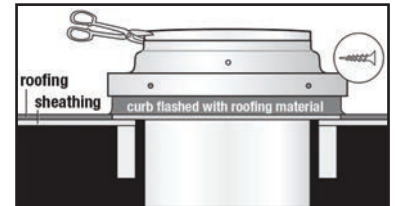

**STEP 18** Place the dome (A) on top of the flashing unit. Secure dome to flashing by screwing in the (4) self-tapping Phillips head 1/4" screws (B) provided into the pre-drilled holes in the dome collar.



**STEP 19** Run power to the LED Driver per local electrical codes and use whichever control method is preferred, either manual switch, wireless remote control or occupancy sensor.

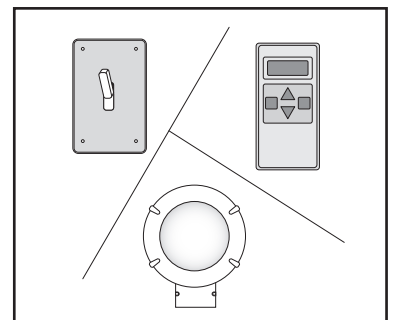



**Natural Light**  
ENERGY SYSTEMS

## Tubular Skylight Limited Warranty

10821 N 23rd Ave, Phoenix, AZ, 85029 • 1.800.363.9865 • www.nltubular.com

**Natural Light Tubular Skylights have a 25-year warranty against manufacturing defects and deterioration. Electrical parts are warranted for 5 years.**

**IMPORTANT: PLEASE COMPLETE AND MAIL THE CARD BELOW AS SOON AS YOUR TUBULAR SKYLIGHT IS INSTALLED.** This card will serve as proof of your purchase, should you misplace your original invoice.

The manufacturer warrants this product and its components to be free from defects in material and manufacturer's workmanship for a period of twenty five years from the date of installation. This warranty is subject to proper installation of the unit in accordance with the manufacturer's written installation instructions. The manufacturer will not be liable for any special, incidental or consequential damages in any way related to, or arising out of, defects in, or damage to, the tubular skylight.

This warranty gives you specific legal rights, and you may have other rights which vary from state to state concerning exclusion or limitation of incidental or consequential damages.

*To register your product, please fill out the form below and mail it to:  
Natural Light Energy Systems • 10821 N 23rd Ave, Phoenix, AZ 85029*

### REGISTRATION

Natural Light Product Installer: \_\_\_\_\_

Customer Name: \_\_\_\_\_ Date of Purchase: \_\_\_\_\_

Address: \_\_\_\_\_

City: \_\_\_\_\_ State: \_\_\_\_\_ Zip: \_\_\_\_\_

Phone: \_\_\_\_\_ Email: \_\_\_\_\_

**Customer Survey** Are you Satisfied with the performance? Y N